

# **E-Bike —LCD Display**

# User manual

**Model:DR-208**

**Tianjin D&R Electronic Technology Co., Ltd.**

# Content

1. Product Name and Mode .....	1
2. Specifications and Parameters .....	1
3. Appearance and Size .....	1
4. Function Overview and Functional Area Distribution .....	3
4.1 Function Overview .....	3
4.2 Functional Area Distribution .....	3
4.3 Button Definitions .....	3
5. Routine Operations .....	4
5.1 Bind NFC Card .....	4
5.1.1 First Bind NFC Card .....	4
5.1.2 Secondary bind NFC card .....	4
5.2 Power ON/Power OFF .....	5
5.2.1 Use Button To Power ON/OFF .....	5
5.2.2 Use NFC Card To Power ON/OFF .....	5
5.3 Display Interface Switching .....	5
5.4 Pedal Assist .....	6
5.5 Headlight ON/OFF .....	6
5.5.1 Manual .....	6
5.5.2 Auto .....	6
5.6 Pedal Assist Level Selection .....	7
5.7 Battery Level .....	7
5.8 Left/Right Turn .....	8
5.9 Single/Dual Drive Mode Change .....	8
5.10 Speed Limit Change .....	9
5.11 Type-C Charge .....	9
5.12 Error Code Displayed .....	9
6. Personalized Parameter Settings .....	10
6.1 Restore Factory Parameters .....	10
6.2 Backlight Brightness Setting .....	10
6.3 Mileage Unit Setting .....	10
6.4 Voltage Setting .....	10
6.5 Auto Shutdown Time Setting .....	10
6.6 Assist Gear Setting .....	10
6.7 Wheel Diameter Setting .....	10
6.8 Speed Sensor Magnet Steel Quantity Setting .....	10
6.9 Speed Limit Setting .....	11
6.10 Startup Mode Setting .....	11
6.11 Drive Mode Setting .....	11
6.12 Assist Sensitivity Setting .....	11
6.13 Pedal Assist Strength Setting .....	11
6.14 Pedal Assist Disk Type Setting .....	11
6.15 Controller Current Limit Setting .....	11
6.16 Under-Voltage Value Setting .....	11
6.17 ODO Reset .....	11
6.19 Auto Headlight Setting .....	11
6.20 Light Sensitivity Setting .....	11
6.21 Startup Password Setting .....	11
6.22 Menu Password Setting .....	11
7. Quality Commitment and Warranty Scope .....	12
7.1 Warranty Information .....	12
7.2 Non-Warranty Scope .....	12
8. Precautions .....	12
Appendix 1: Error Code Definition Table .....	12

### 1. Product Name and Mode

E-Bike Intelligent LCD Display, Model: DR-208, with Button Model: F9

### 2. Specifications and Parameters

- Power Supply: 24V/36V/48V/52V
- Rated Operating Current: 15mA
- Maximum Operating Current: 30mA
- Shutdown Leakage Current: <1uA
- Controller Supply Current: 50mA
- Operating Temperature: -10 ~ 60°C
- Storage Temperature: -30 ~ 70°C

### 3. Appearance and Size



Figure 3-1: F9 Button Physical Image



Figure 3-2: DR-208 Instrument Physical Image

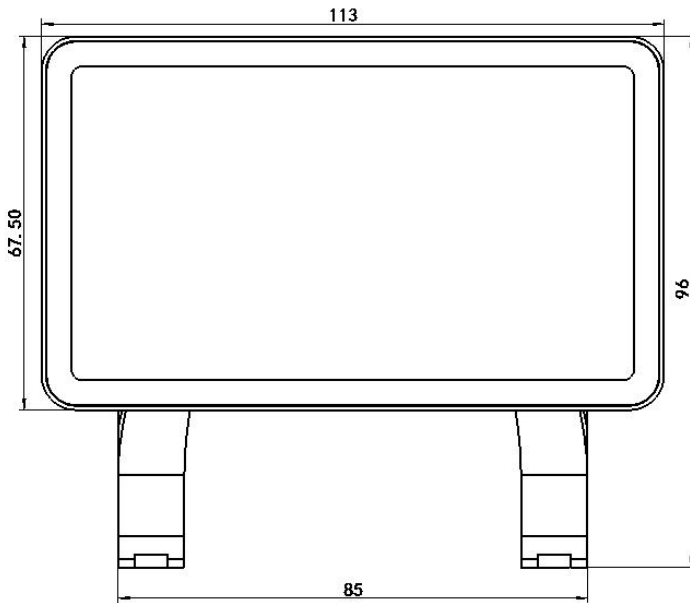

Figure 3-3: DR-208 Instrument Front View Dimensions

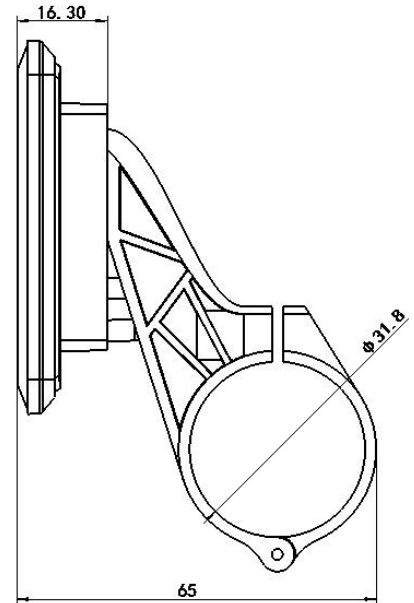

Figure 3-4: DR-208 Instrument Side View Dimensions

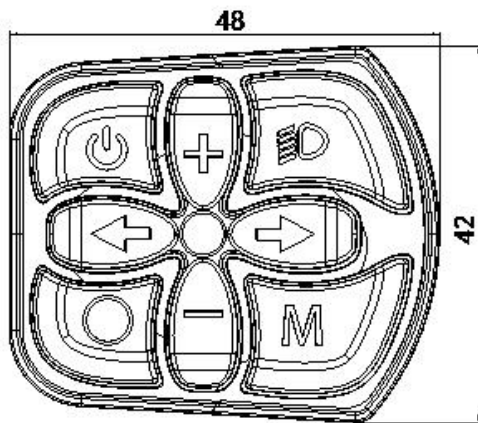

Figure 3-5: F9 Button Front View Dimensions

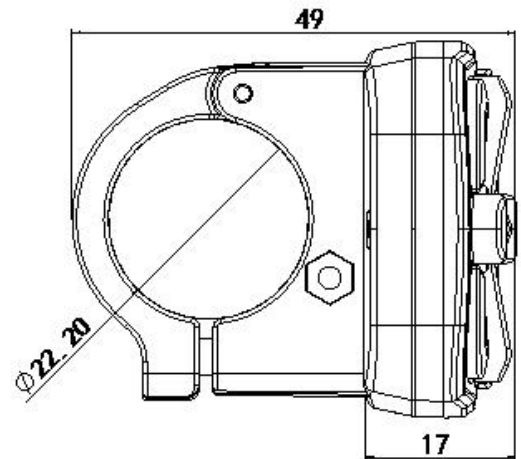

Figure 3-6: F9 Button Side View Dimensions

## 4. Function Overview and Functional Area Distribution

### 4.1 Function Overview

The DR-608 display provides multiple functions to meet your cycling needs, including:

- Battery Level Display
- Speed Display
- Pedal Assist Level Adjustment and Display
- Mileage Display (single trip mileage and total mileage)
- Pedal Assist Control and Display
- Left/Right Turn Control and Display
- Headlight Control and Display
- Cruise Control Display
- Type-c Charge
- NFC Card On and Off
- Automatic Sensing Headlights
- Error Code Display
- Personalized Parameter Settings (e.g., wheel diameter, speed limit, etc.)
- Restore Factory Parameters

### 4.2 Functional Area Distribution

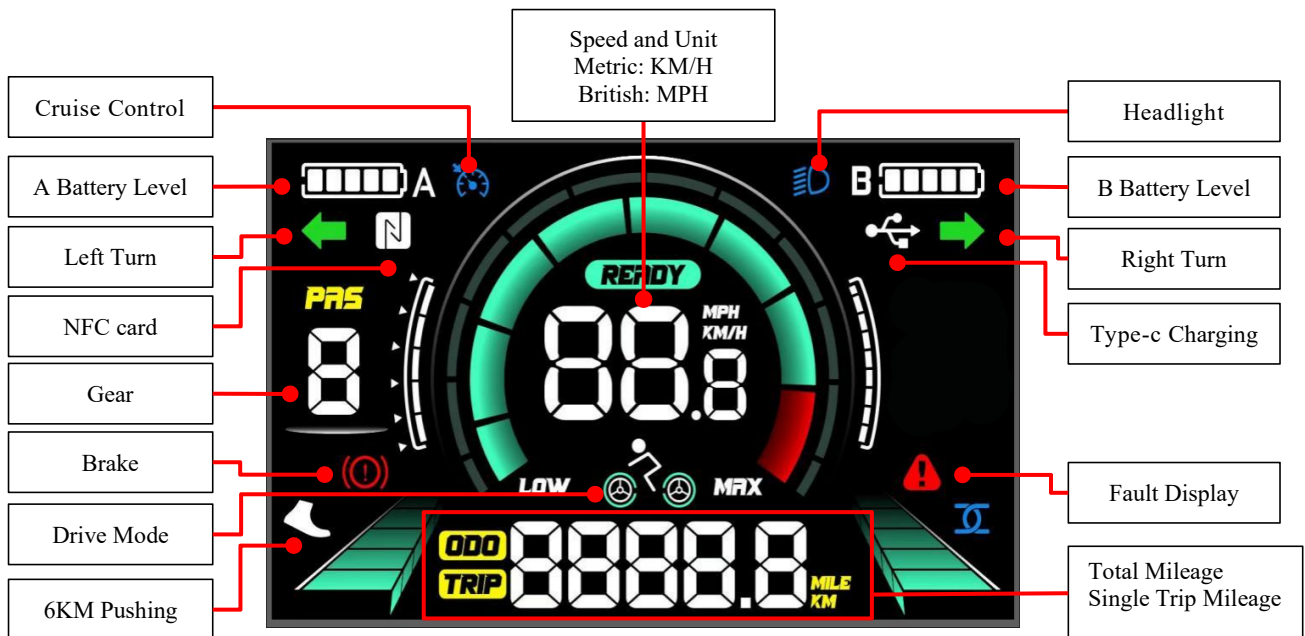









Figure 4-1: DR-208 Functional Area Distribution Interface

### 4.3 Button Definitions

There are 8 keys on the F9 button, and their functions are:

- On/Off Key 、Headlight Key 、Single / dual drive switch key 、Function key 、UP key 、  
Down key 、Left Turn key 、Right Turn key 

## 5. Routine Operations

### 5.1 Bind NFC Card

#### 5.1.1 First Bind NFC Card

For the first power-on, the instrument enters the card binding program and displays nFc/C-1, At this point, stick the NFC card on the screen, and nFc/C-2 will be displayed. Then stick the second NFC card on the screen, and so on. Four NFC cards can be bound. Then press any key of the button. If "oFF" is displayed, it indicates that the card binding is successful. By default (By default, there are two NFC cards. After the second card is attached, press any key on the button. If "oFF" is displayed, it indicates that the two cards have been successfully bound)



The first NFC card



The second NFC card



The third NFC card



The fourth NFC card

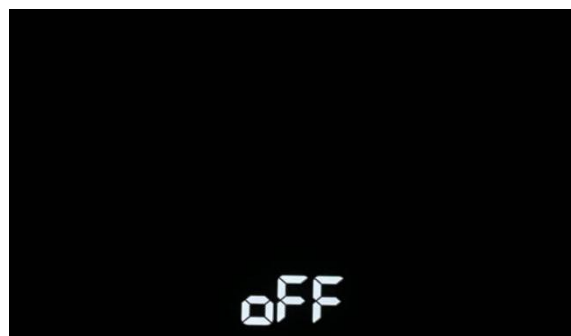





Figure 5-1: Binding Card Display Interface

#### 5.1.2 Secondary bind NFC card

Within 10 seconds after the instrument is turned on, press the  to turn the headlight on and off 7 times. Then wait for 1 second. The instrument will enter the card binding program. At this point, you can bind the NFC card for the second time. The card binding method is "refer to the process of first NFC card binding in 5.1.1"

## 5.2 Power ON/Power OFF

### 5.2.1 Use Button To Power ON/OFF

Short press the  to start the instrument and connect the controller's power supply; In the powered-on state, Long press the , the instrument will shut down and stop working. (If you set a startup password, you will be prompted to enter the password after startup, and you can start the device normally by entering the password or swiping NFC card on this screen)

### 5.2.2 Use NFC Card To Power ON/OFF

Attach the NFC card to the instrument screen, turn on the instrument, and connect the working power supply of the controller. When the device is turned on, attach the NFC card to the instrument screen again. The instrument will then shut down and stop working. (If a startup password is set, the NFC startup will skip the password entry interface)

**⚠️ If the E-bike is not used for more than 10 minutes, the instrument will automatically shut down.**

## 5.3 Display Interface Switching

Main interface display: battery power, real-time speed, gear value, total mileage (ODO) .

Short press the  to switch between total mileage (ODO) and single mileage (TRIP) data.



Figure 5-2: Display Interface Switching

## 5.4 Pedal Assist



When the vehicle has no speed, long press the  key, and the power-assisted vehicle will enter the power-assisted pushing state. Drive at a constant speed of 6KM/H, The interface will display . Release the button to exit the push mode.





Figure 5-3: Pedal Assist Display Interface

**⚠** The pedal assist function can only be used when the user is pushing the E-bike. Do not use it while riding.

## 5.5 Headlight ON/OFF

### 5.5.1 Manual

Short press the  to turn on the headlights, the backlight of the instrument will be dimmed and display ; short press the  again to turn off the headlights, and the backlight of the instrument will be restored.

### 5.5.2 Auto

When the usage environment darkens (such as entering a tunnel, dusk, encountering a cloudy day, or entering an underground garage), the headlights will automatically turn on and the backlight of the instrument panel will dim;

When the usage environment becomes brighter (such as: exiting a tunnel, dusk, encountering a cloudy day, entering an underground garage), the headlights will automatically turn off and the instrument backlight will regain its brightness.



Figure 5-4: Headlight Display Interface

### 5.6 Pedal Assist Level Selection



Short press the  or  to change the E-bike pedal assist levels, thereby changing the motor output power.



Figure 5-5: Level Switch Display

### 5.7 Battery Level

The battery level is displayed in five segments. When the battery is fully charged, all five segments are lit. When the battery is under-voltage, the outer frame of the battery blinks, indicating that it needs to be charged immediately.

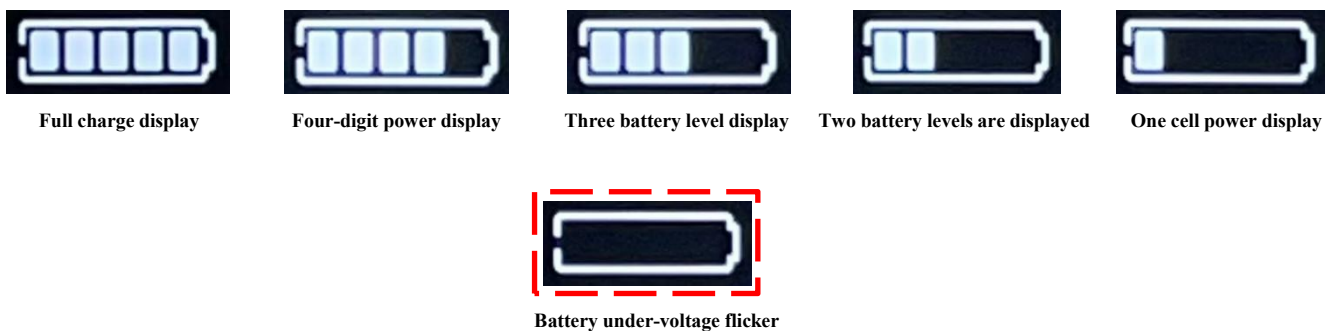



Figure 5-6: Battery Level Display Interface

### 5.8 Left/Right Turn

Short press the  or  to turn on the left or right turn signal light on the electric bike (the turn signal light blinks when turned on), and the corresponding turn indicator on the instrument blinks. Short press the  or  again to turn off the turn signal.





Left turn indicator flashes



Right turn indicator flashes

Figure 5-7: Left/Right Turn Indicator Display Interface

### 5.9 Single/Dual Drive Mode Change

Short press the  to change between single and dual drive modes, the interface displays  "rear wheel" blinking, representing single drive mode the interface displays  "front and rear wheels" blinking simultaneously, representing dual drive mode.





Single drive mode



Dual drive mode

Figure 5-8: Single/Dual Drive Mode Display Interface

### 5.10 Speed Limit Change

Long press the  to cancel the speed limit (64MPH), the interface displays "64"; long press the  key again to limit speed to 20MPH, the interface displays "20". The default speed limit is 20MPH each time the machine is turned on.

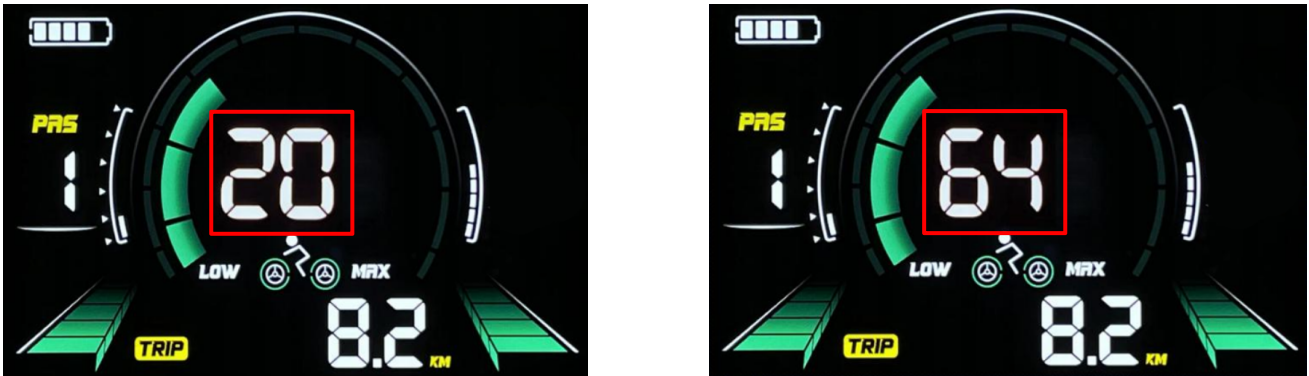

Figure 5-9: Speed limit Display Interface

### 5.11 Type-C Charge



Long press the  for 2 seconds, the interface displays , indicating that the Type-C charging function is turned on, and it can mobile phones or other digital products. Press the  for 2 seconds again to turn off the Type-C charging function.



Figure 5-10: Type-C Charging Display Interface

### 5.12 Error Code Displayed

When the E-bike electronic control system encounters a fault, the display will automatically show the error code. For detailed definitions of error codes, refer to **Appendix 1**.



Figure 5-11: Error Code Display Interface









 When the display interface shows an error code, please troubleshoot the issue promptly. The electric bike will not function properly if a fault occurs.

## 6. Personalized Parameter Settings

**⚠ All settings must be performed while the vehicle is stationary.**

Steps for Personalized Parameter Settings:

When the device is powered on and the display shows a speed of 0

- (1) Long press the  for more than 2 seconds to enter the personalized parameter settings selection interface;
- (2) Short press the  to cycle through the personalized parameter settings interface;
- (3) Short press the  or  to select parameters, long press the  for continuous addition, and long press the  for continuous subtraction;
- (4) After adjusting the parameters, short press the  to save the settings and switch to the next parameter settings interface;
- (5) Long press the  to save the settings and exit the personalized parameter settings interface, returning to the main interface.

The personalized parameter settings interface includes the following options:

### 6.1 Restore Factory Parameters

**00P** is the option for setting restore factory;"dEF-n" represents the no restoration, and "dEF-y" represents the restoration of factory parameters.

### 6.2 Backlight Brightness Setting

**01P** is the option for setting backlight brightness;The set values are 1, 2, and 3. 1 is the darkest, 3 is the brightest, Default:3.

### 6.3 Mileage Unit Setting

**02P** is the option for setting mileage units;0 (KM) represents the metric , 1 (MILE) represents the imperial, Default: 1 (MILE)。

### 6.4 Voltage Setting

**03P** is the option for setting voltage;The set values are 24V,36V, 48V, and 52V, Default: 48V.

### 6.5 Auto Shutdown Time Setting

**04P** is the option for setting auto shutdown time;00 represents the no auto shutdown,Other number represents the auto shutdown time,Set the range from 00 to 60,Unit: Min,Default:10.

### 6.6 Assist Gear Setting

**05P** is the option for setting Assist gear,The set values are 3 and 5.3 is the 0-3gear,5 is the 0-5gear,Default: 5.

### 6.7 Wheel Diameter Setting

**06P** is the option for setting Wheel Diameter,Set the range from 05 to 50,Unit: inch,precision:0.1,Default: 24.

### 6.8 Speed Sensor Magnet Steel Quantity Setting

**07P** is the option for setting the Speed sensor magnet steel quantity,The setting range is 1 to 100 , Default: 6.

(This setting is related to the speed display, and the setting value should be accurate)

(Ordinary motor setting corresponding to the number of magnetic steel)

(High-speed motor, need formula calculation, Formula:magnet steel quantity X Reduction ratio;

For Example:magnet steel is 20,the reduction ratio is 4.3,then the setting value is  $86=20 \times 4.3$ )

## 6.9 Speed Limit Setting

08P is the option for setting the speed limit. Set the range from 1 to 100 km/h, Default: 32 km/h.

## 6.10 Startup Mode Setting

09P is the option for setting startup mode, 0 represents the zero startup, 1 represents the non-zero startup, Default: 0.

## 6.11 Drive Mode Setting

10P is the option for setting drive mode, 0 represents the power-assisted drive, 1 represents the electric drive, 2 represents the coexistence of power-assisted drive and electric drive, Default: 2.

## 6.12 Assist Sensitivity Setting

11P is the option for setting assist sensitivity, Set the range from 1 to 24, Default: 2.

## 6.13 Pedal Assist Strength Setting

12P is the option for setting pedal assist strength, Set the range from 1 to 5, Default: 3.

## 6.14 Pedal Assist Disk Type Setting

13P is the option for setting pedal assist disk type, The set values are 5, 8, and 12, Default: 12.

## 6.15 Controller Current Limit Setting

14P is the option for setting controller current limit, Set the range from 1 to 45, Default: 44.

## 6.16 Under-Voltage Value Setting

15P is the option for setting under-voltage value, Set the range from 36 to 44, precision: 0.1, Default: 40.

## 6.17 ODO Reset

16P is the option for setting ODO reset, Long press the  5 seconds ODO Reset

## 6.18 Cruise Control Setting

17P is the option for setting cruise control, 0 represents the cruise control is disabled, 1 represents the cruise control is enabled, Default: 1.

## 6.19 Auto Headlight Setting

18P is the option for setting auto headlight, LAP-n represents the auto headlight disabled, LAP-y represents the auto headlight enabled, Default: LAP-y.

## 6.20 Light Sensitivity Setting

19P is the option for setting light sensitivity, Set the range from 1 to 100, Default: 40.

## 6.21 Startup Password Setting

20P is the option for setting startup password, oPd-n represents the startup password disabled, oPd-y represents the startup password enabled, Default: oPd-y, Default password: 1212.

 **You can set and change other four-digit passwords by yourself.**

## 6.22 Menu Password Setting

21P is the option for setting menu password, Std-n represents the menu password disabled, Std-y represents the menu password enabled, Default: Std-y, Default password: 1313.

 **You cannot set or change other passwords by yourself.**

## 7. Quality Commitment and Warranty Scope

### 7.1 Warranty Information

- For any malfunction caused by product quality issues under normal usage conditions, our company will provide limited warranty service within the warranty period.
- The warranty period for the product is 12 months from the date of manufacture of the display.

### 7.2 Non-Warranty Scope

- The casing has been opened.
- The connectors have been damaged.
- Scratches or damage to the casing after the instrument has been manufactured.
- Damage to the display' s wiring.
- Malfunctions or damage caused by irresistible forces (such as fire, earthquake, etc.) or natural disasters (such as lightning strikes, etc.).
- The product is beyond the warranty period.

## 8. Precautions

- ◆ Pay attention to safety during use. Do not plug or unplug the instrument while it is powered on.
- ◆ Avoid bumps and knocks to the display.
- ◆ Do not change the background parameter settings of the display casually, as this may affect normal riding.
- ◆ If the display cannot be used normally, please send it for repair as soon as possible.
- ◆ Due to product upgrades, the display content or functions of the product you receive may differ from the instructions. The actual product should be taken as the standard.

### Appendix 1: Error Code Definition Table

Error Codes for Protocol 2:		
Error Code	Status Meaning	Resolution
Error05	Brake Fault	Check if the brake is in position; replace the brake lever if necessary.
Error06	Battery under voltage	Battery needs charging.
Error07	Motor Fault	Check if the power line is loose.
Error08	Throttle Fault	Check if the throttle is in position; inspect the throttle connection, and replace the throttle if normal.
Error09	Controller Fault	Check the controller Hall connection.
Error10	Communication Receive Fault	Check if the instrument cable is properly connected.
Error11	Communication Transmit Fault	Check if the instrument cable is properly connected.